

Direct Drive, Gas Engine Flange Models

1" Hollow Shaft, SAE J609-B Flange and Set Screw
3400 RPM

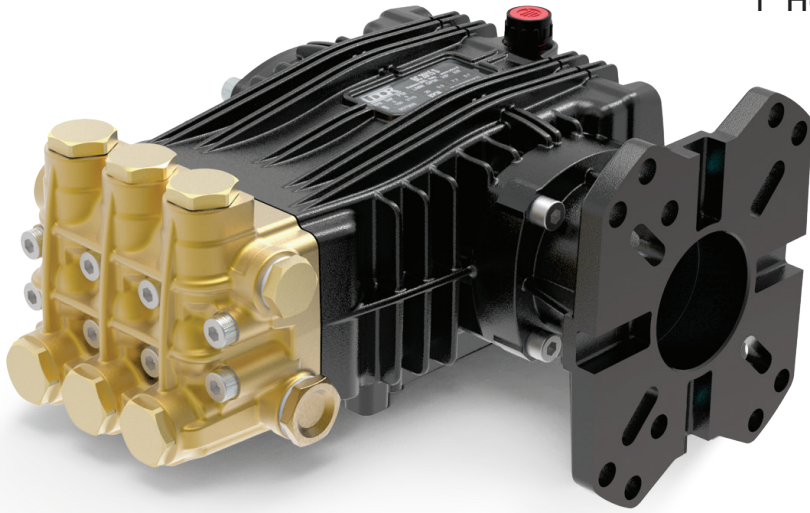

- Heavy Duty Brass Manifold with External and Internal Bracing
- Heavy Duty Bronze or High Strength Aluminum Alloy Connecting Rods.
- Large Diameter Brass Valve Caps with Increased Thread Depth
- Reinforcing Ring on Inlet and Discharge Ports
- Deeper Back Cover for Increased Oil Capacity
- 15.4 oz. Capacity Vented Oil Bath Crank Case
- 1/2" BSP-F Inlet. 3/8" BSP-F Outlet
- Max Fluid Temp, 160°F

BKL Series Direct Drive, Gas Engine Flange Plunger Pumps

BKL Series super duty plunger pumps include a range of models with flow rates from 4.0 to 5.0 GPM and pressures up to 4350 PSI.

Other drive options include 24mm solid shaft, gas engine gear reduction and hydraulic motor flange.

Applications include general pressure cleaning, sewer jetting, vehicle wash equipment and UHP fire fighting applications.

	Model	Flow		Pressure		Plunger Dia.	Crankshaft		Power	Seal Kit	Valve Kit	Wt.
		GPM	l/min	PSI	bar		Stroke	Code				
3400 RPM	BKL 4.0/44 W	4.0	15.0	4350	300	15mm	10.0mm	5	14.5 HP Gas	6061.B2	6061.30	26 lbs
	BKL 5.0/36 W	5.0	19.0	3625	250	15mm	12.0mm	6	16 HP Gas	6061.B2	6061.30	26 lbs

NOTE: All pump models available with left-hand drive option. Add 'L' to model number when ordering (ex. BKL 5.0/36 WL)

MAX OUTPUT
MAX OUTPUT
RATED PUMP SPEED
POWER REQUIREMENT
LUBRICATION

5.0 GPM / 19.0 L/MIN
3625 PSI / 250 BAR
3400 RPM
16.0 HP GAS ENGINE
15.4 OZ UDOR LUBE

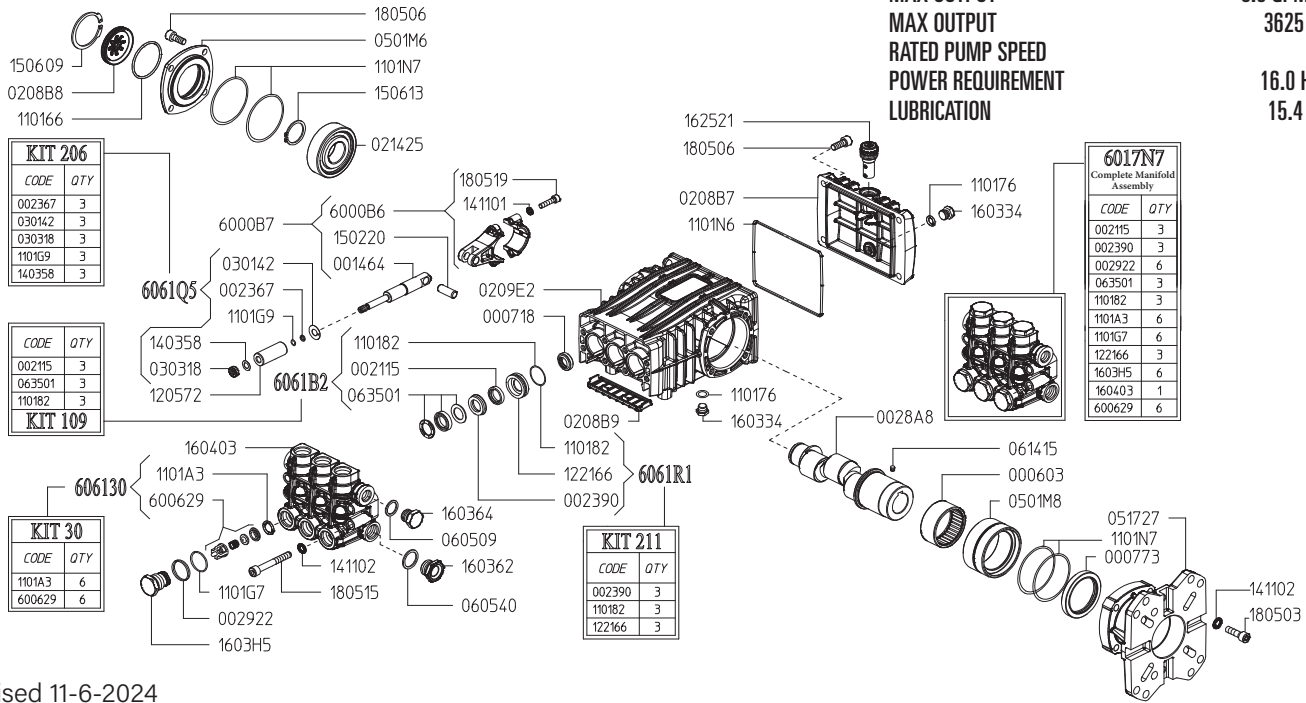

Revised 11-6-2024

Part #	Description	Qty	Part #	Description	Qty
0006.03	BUSHING D50	1	1101.N7	O-RING - BEARING FLANGE	4
0007.18	OIL SEAL D15X24X5	3	1205.72	CERAMIC PLUNGER D15 "B/BK"	3
0007.73	OIL SEAL D50	1	1221.66	PRESSURE RING D15 "B/BK" ^{D E}	3
0014.64	PLUNGER GUIDE "B/BK"	3	1403.58	WASHER D8 ^C	3
0021.15	WATER SEAL LP D15 ^{B E}	3	1411.01	SERATED WASHER D6	6
0023.67	RING D5.2X8X1.3 ^C	3	1411.02	SERATED WASHER D8	8
0023.90	UPPER RING D15 "B/BK" ^{D E}	3	1502.20	PIN D10X27	3
0028.A8	HOLLOW SHAFT "B/BK" D1"	1	1506.09	SNAP RING D52	1
0029.22	RING "CK" D15.2 ^E	6	1506.13	SNAP RING D30	1
0208.B7	BACK COVER "B/BK"	1	1603.34	PLUG G1/4	2
0208.B8	OIL SIGHT GLASS	1	1603.62	PLUG G1/2	1
0208.B9	COVER "B/BK"	1	1603.64	PLUG G3/8	1
0209.E2	CRANKCASE "B-X/BK-X"	1	1603.H5	VALVE PLUG "BK" ^E	6
0214.25	BEARING D30	1	1604.03	HEAD "BK-X" ^E	1
0301.42	SLINGER RING ^C	3	1625.21	OIL PLUG G3/8	1
0303.18	NUT M8XH5 ^C	3	1805.03	ALLEN BOLT M8X30	4
0501.M6	BEARING FLANGE "B/BK"	1	1805.06	ALLEN BOLT M8X20	8
0501.M8	BEARING FLANGE "B/BK"	1	1805.15	ALLEN BOLT M8X60	8
0517.27	ENGINE FLANGE "B/BK" HP7/18	1	1805.19	ALLEN BOLT M6X25	6
0605.09	GASKET D17X23X1.5	1	6000.B6	ROD ASSEMBLY "B/BK"	3
0605.40	GASKET D21.5X27X1.5	1	6006.29	VALVE ASSEMBLY WITHOUT O-RING ^{A E}	6
0614.15	SET SCREW M5X8		6017.N7	COMPLETE MANIFOLD ASSEMBLY	1
0635.01	HIGH PRESSURE SEAL KIT D15 ^{B E}	3	6061.30	KIT 30 - VALVE KIT "BK"	1
0801.17	KEY A8X7X35	1	6061.B2	KIT 109 - WATER SEAL KIT	1
1101.66	O-RING - OIL SIGHT GLASS	1	6061.Q5	KIT 206 - PLUNGER KIT D15/18 "B/BK"	1
1101.76	O-RING - PLUG	2	6061.R1	KIT 211 - BRASS RING KIT D18 "B/BK"	1
1101.82	O-RING - PRESSURE RING ^{B D E}	3			
1101.A3	O-RING - VALVE ^{A E}	6			
1101.G7	O-RING - VALVE PLUG ^E	6			
1101.G9	O-RING - PLUNGER ROD ^C	3			
1101.N6	O-RING - REAR COVER	1			

A Parts in 6061.30 (Kit 30).
B Parts in 6061.B2 (Kit 109).
C Parts in 6061.Q5 (Kit 206).
D Parts in 6061.R1 (Kit 211).
E Parts in 6017.N7 (Complete Manifold Assembly).

*Dimensional Drawings are
Shown in Millimeters.
To Convert to Inches,
Multiply Dimension x 0.03937*

BK SERIES PUMPS - 1" HOLLOW SHAFT w/ GAS ENGINE FLANGE

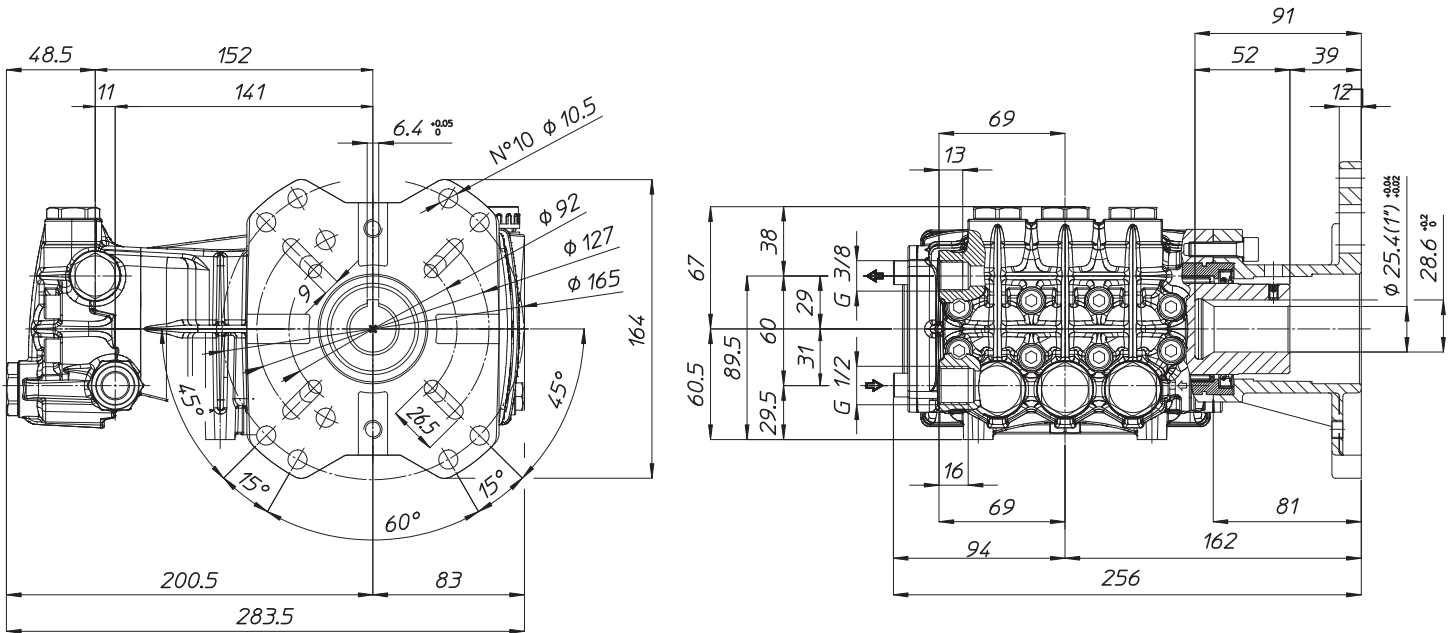

TORQUE SPECS

Ref.	Description	Ft./lb.	Nm	Loctite®
1	Head Bolts	19	25	-
2	Valve Caps	75	100	243
3	Inlet Cap	75	100	243
4	Outlet Cap	60	80	243
5	Bearing Flange Bolts	19	25	-
6	Rear Cover Bolts	19	25	-
7	Connecting Rod Bolts	9	11	243
8	Plunger Bolts	11	15	270
9	Valve Cover Bolts	-	-	-
10	Oil Drain Plug	19	25	-

